

MARTIN AUTOMATIC TURRET UNWIND STAND

Hheavy roll weights demand independent unwind stands for web delivery to the splicer and process. Martin's Turret Unwind offers many features not available in most unwinds today. Motorized sidelay for web alignment to the running roll assures the operator the splice will align to the process. Independently adjustable roll handling arms offer the versatility of variable-sized webs without shutting the process down for change over and requires no tools.

Martin Turret Unwind stands can be application-engineered to fit each process. Variable-sized web width capability offers flexibility many unwinds lack. Martin Unwinds are available

for web widths to 80 inches, roll diameters to 84 inches and roll capacity to 10,000 lbs. Larger roll capacities are available on request.

Optionally, your Turret Unwind can be configured to unwind rolls in either direction, or include automatic sidelay for continuous running roll adjustment.

The Martin Turret Unwind is an ideal complement to the Martin Butt Splicer for board. Consult Martin for your application requirements.

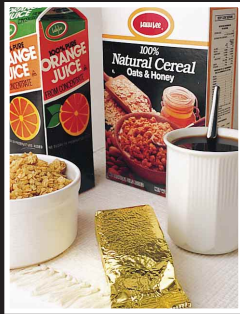

Consistently printed and converted packaging is essential for success. Martin products aid printers and converters in meeting consumer expectations and production demands.



Martin Engineers Solutions!

TURRET UNWIND STAND DIMENSIONS & SPECIFICATIONS

Martin's **TURRET-STYLE UNWIND** Offers

- Automatic roll centering after loading each roll
- Chucks for 12 inch cores with options available from 3 to 16 inches
- Heavy-duty welded construction
- Motorized sidelay with 1 1/2 inch of adjustment
- Martin designed air-cooled, high-torque disc brakes
- Operator and gear side chucks extend and retract for easy roll loading and unloading
- Pneumatic chucks inflate to engage cores with out damage
- Turnover drive
- Two roll positions
- Variable web-width capability (new roll to running roll)
- Automatic shut-down when roll is driven into the ground

As with all Martin products, the Martin TURRET UNWIND STAND can be application-engineered to fit each process. Contact Martin Automatic for your specific needs.

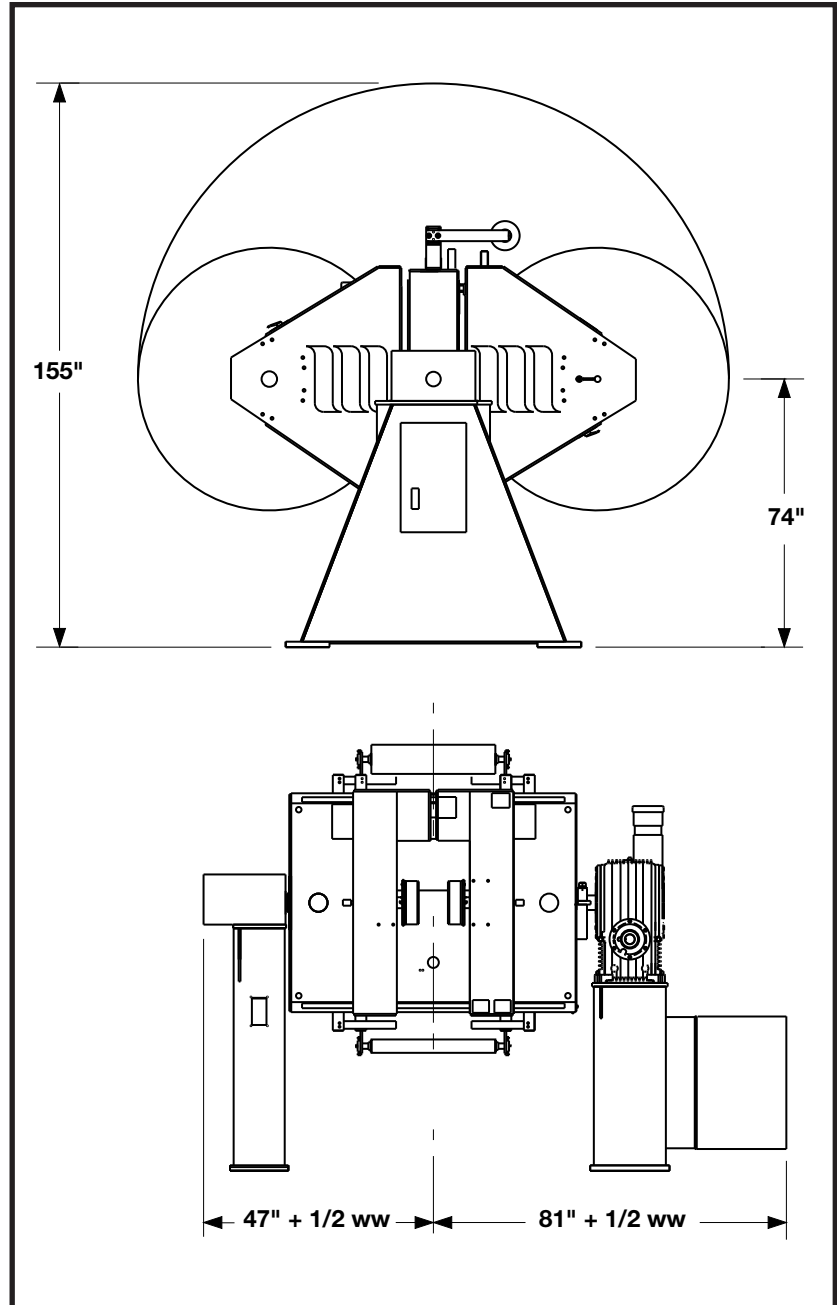

Footprint dimensions will depend on roll diameter and web width. Dimensions shown are for 72 inch diameter, 6000 lb roll. Call Martin with your process specifications.



Martin Automatic Inc

1661 Northrock Ct
Rockford, Illinois 61103, U.S.A.
Tel: (815) 654-4800 • Fax: (815) 654-4810